

Communication IC for Automotive Battery Applications

KA84922UA Product Brief

The information described in this document is the exclusive intellectual property of Nuvoton Technology Corporation Japan and shall not be reproduced without permission from Nuvoton.

Nuvoton is providing document only for reference purposes of KA84922UA Communication IC based system design. Nuvoton assumes no responsibility for errors or omissions.

All data and specifications are subject to change without notice.

For additional information or question, please contact Nuvoton Technology Corporation Japan.

www.nuvoton.co.jp

■ IMPORTANT NOTICE

Regarding the specifications of this product, it is considered that you have agreed to the quality level and disclaimer described below.

Support for industry standards and quality standards

| | |
|-------------------------------------------------------------|--------------|
| Functional safety standards for automobiles ISO26262 | Yes |
| AECQ-100 | Yes |
| Market failure rate | 10Fit |

Disclaimer

1. When the application system is designed using this IC, please design the system at your own risk. Please read, consider, and apply appropriate usage notes and description in this standard.
2. When designing your application system, please take into the consideration of break down and failure mode occurrence and possibility in semiconductor products. Measures on the systems such as, but not limited to, redundant design, mitigating the spread of fire, or preventing glitch, are recommended in order to prevent physical injury, fire, social damages, etc. in using the Nuvoton Technology Japan Corporation (hereinafter referred to as NTCJ) products.
3. When using this IC, for each actual application systems, verify the systems and the all functionality of this IC as intended in application systems and the safety including the long-term reliability at your own risk
4. Please use this IC in compliance with all applicable laws, regulations and safety-related requirements that regulate the inclusion or use of controlled substances, including without limitation, the EU RoHS Directive. NTCJ shall not be held responsible for any damage incurred as a result of this IC being used not in compliance with the applicable laws, regulations and safety-related requirements.
5. This IC does not have any security functions using cryptographic algorithms, such as authentication, encryption, tampering detection.
6. Unless this IC is indicated by NTCJ to be used in applications as meeting the requirements of a particular industry standard (e.g., ISO 9001, IATF 16949, ISO 26262, etc.), this IC is neither designed nor intended for use in such environments for that applications. NTCJ shall not be held responsible for not meeting the requirements of a particular industry standard.
7. Using IC that have been indicated as compliant with industry functional safety standards does not warrant that the application meets the requirements of industry functional safety standards. NTCJ shall not be held responsible for the application compliance with requirements of the particular industry functional safety standard.
8. Unless this IC is indicated by NTCJ to be used in applications as meeting the requirements of a particular quality standard (e.g., AECQ-100, etc.), this IC is neither designed nor intended for use in such the environments for that applications. NTCJ shall not be held responsible for not meeting the requirements of a particular quality standard.
9. In case of damages, costs, losses, and/or liabilities incurred by NTCJ arising from customer's non-compliance with above from 1 to 8, customer will indemnify NTCJ against every damages, costs, losses and responsibility.

KA84922UA Product Brief

Automotive Communication IC for Multi-cell Stacked Battery System

FEATURES

- Converts SPI protocol to differential data stream
- Simple electrical insulation using standard transformer
- Dual 4MHz serial interface with packet error check
- Bidirectional daisy communication up to 2.5Mbps (Support upper and lower side communication)
- Dual channel bidirectional daisy communication
- Alarm detection capability with MCU wakeup function during low power consumption mode
- Designed for ISO26262-compliant safety systems, up to ASIL-D
- AEC-Q100 Compliant
- Operating temperature range : -40 to 125degC
- Package : TSSOP type 24 pins

DESCRIPTION

KA84922UA is a communication IC that converts 2 channels of SPI protocol to differential data stream. It can communicate with slave devices such as battery monitoring IC (KA84950UA, KA84930UA), pack monitoring IC (KA84917UA) via an isolation device, such as transformer. The communication IC also supports a low power consumption mode that detects alarm signal from the battery monitoring IC and wakes up the external LDO which supplies power to the MCU, during an abnormal event.

APPLICATIONS

- Electric vehicle (EV)
- Plug in hybrid electric vehicles (PHEV)
- Hybrid electric vehicles
- Power applications which utilize multi stacked battery Cells

TYPICAL APPLICATION

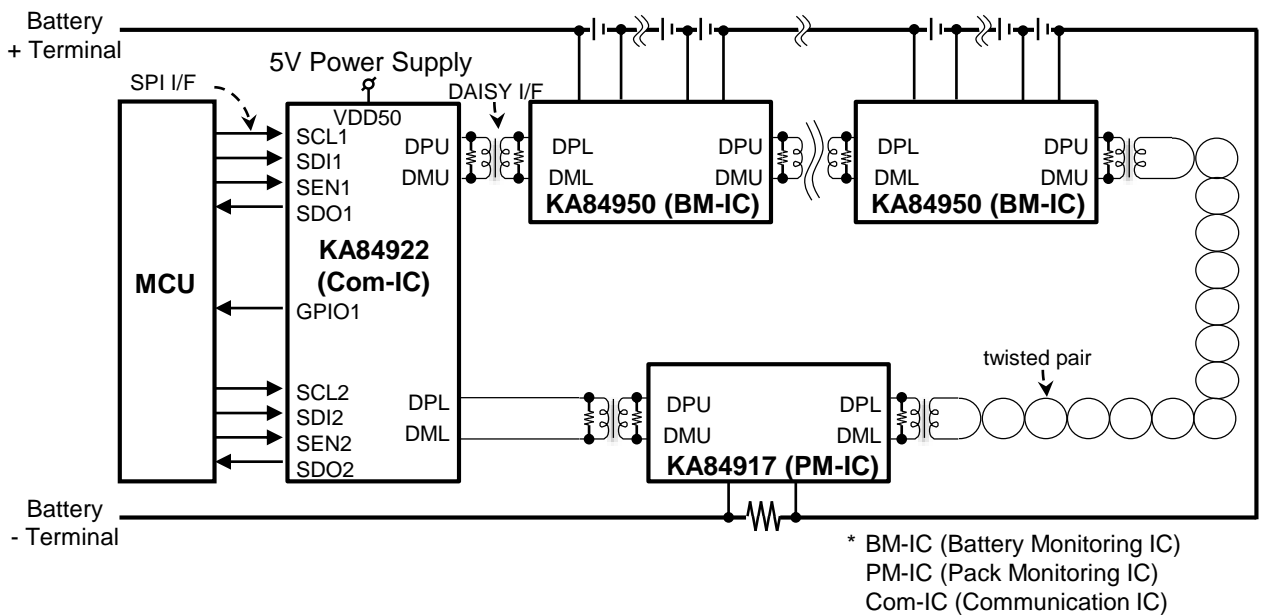

Note)

This application circuit is an example. The operation of the mass production set is not guaranteed. Customers shall perform enough evaluation and verification on the design of mass production set. Customers shall be fully responsible for the incorporation of the above application circuit and information in the design of the equipment.

Dimensions

TSSOP24L 4.4 x 7.8mm², Thickness 0.90mm, Lead Pitch 0.65mm, Lead Length 1.00mm

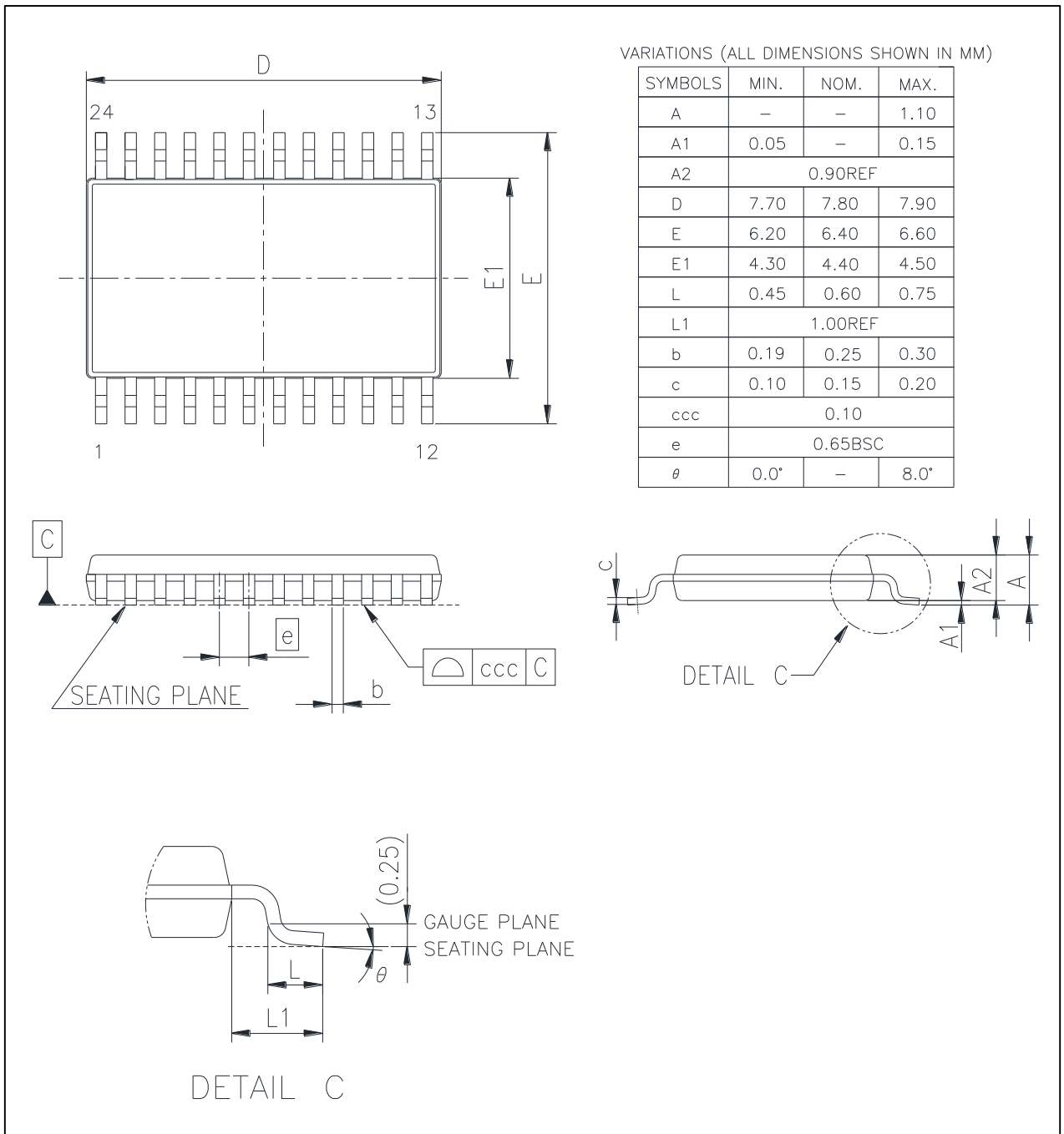

KA84922UA Product Brief

Usage Notes

1. Pay attention to the direction of the IC. When mounting it in the wrong direction onto the PCB (printed-circuit-board), it might be damaged.
2. Pay attention in the PCB (printed-circuit-board) pattern layout in order to prevent damage due to short circuit between pins. In addition, refer to the Pin Description for the pin configuration.
3. Perform visual inspection on the PCB before applying power, otherwise damage might happen due to problems such as solder-bridge between the pins of the IC. Also, perform full technical verification on the assembly quality, because the same damage possibly can happen due to conductive substances, such as solder ball, that adhere to the IC during transportation.
4. Take notice in the use of this IC that it might be damaged when an abnormal state occurs such as output pin – power supply pin (VDD50, CVDD, VCHG) short (Power supply fault), output pin-GND short (Ground fault), output-to-output-pin short (load short), or leakage current between pins. Safety measures such as installation of fuses are recommended because the extent of the above-mentioned damage will depend on the current capability of the power supply.
5. The protection circuit is for maintaining safety against abnormal operation. Therefore, the protection circuit should not work during normal operation. Especially for the thermal protection circuit, if the area of safe operation or the absolute maximum rating is momentarily exceeded due to Power supply fault, or Ground fault, the IC might be damaged before the thermal protection circuit could operate.
6. Verify the risks which might be caused by the malfunctions of external components.

Important Notice

Nuvoton Products are neither intended nor warranted for usage in systems or equipment, any malfunction or failure of which may cause loss of human life, bodily injury or severe property damage. Such applications are deemed, "Insecure Usage".

Insecure usage includes, but is not limited to: equipment for surgical implementation, atomic energy control instruments, airplane or spaceship instruments, the control or operation of dynamic, brake or safety systems designed for vehicular use, traffic signal instruments, all types of safety devices, and other applications intended to support or sustain life.

All Insecure Usage shall be made at customer's risk, and in the event that third parties lay claims to Nuvoton as a result of customer's Insecure Usage, customer shall indemnify the damages and liabilities thus incurred by Nuvoton.

*Please note that all data and specifications are subject to change without notice.
All the trademarks of products and companies mentioned in this datasheet belong to their respective owners.*